



LOW-PRESSURE REDUCER LPR® W wafer design DN 50

Application

The self contained low pressure reducing regulators and back pressure regulators controls pressure in mbar range. Applications are for inert gas tank blanketing, reactors, centrifuges and agitating tubs with inert gas such as nitrogen. The regulators are designed to meet requirements in the chemical, pharmaceutical and biotechnology industries and are particularly corrosion resistant and reliable.

Design

The large proportioned, spring-loaded diaphragm actuator with directly-controlled valve seat ensures precise control with low hysteresis. The regulators function without auxiliary power supply. High overpressure strength and safe regulator function is achieved by means of the supported diaphragm with long spindle guide. The regulator has a low degree of clearance volume and is self-draining, as far as is possible.

Description

The components coming in contact with the product are manufactured from CrNiMo steel 1.4435 / 1.4404. The diaphragm and seals are made of PTFE and the regulator seat is made of perfluoroelastomer (FFKM – Isolast®, Chemraz®, Kalrez®) as standard, or fluoroelastomer (FKM: Viton®). These materials guarantee high corrosion resistance and excellent sealing, even at zero flow. The design has a low degree of clearance volume and is self-draining (suitable for CIP). On request, we can supply regulators in Hastelloy, Tantal or plastic etc. with the appropriate certification. The surface finish for the stainless-steel version is better than Ra 1.6 for housing parts in contact with the medium, better than Ra 0.8 for internal functional parts and better than Ra 3.2 for the outer housing.

Technical data

| | |
|--------------------------------|--|
| Nominal diameter: | DN 50 / 2" |
| Regulating range P2: | L.. to 500 mbar M.. to 5 bar D (pressure difference) to 4 bar = P3 |
| Inlet pressure P1: | max. 10 bar |
| Vakuum proof | |
| Pressure connections: | Flange (Special version available on request) |
| Weight: | 11,3 kg to 12,2 kg |
| Temperature: | -20 ° to +120 °C for EPDM (Dependent on pressure conditions) -20 ° to +130 °C for FKM -20 ° to +160 °C for PTFE |
| Testing and inspection: | According to IEC 60534-4 |
| Pressure tightness: | Sealing category V |

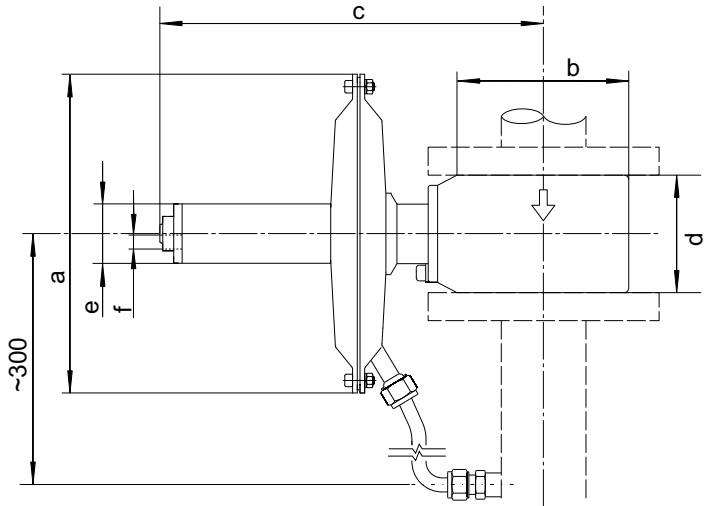
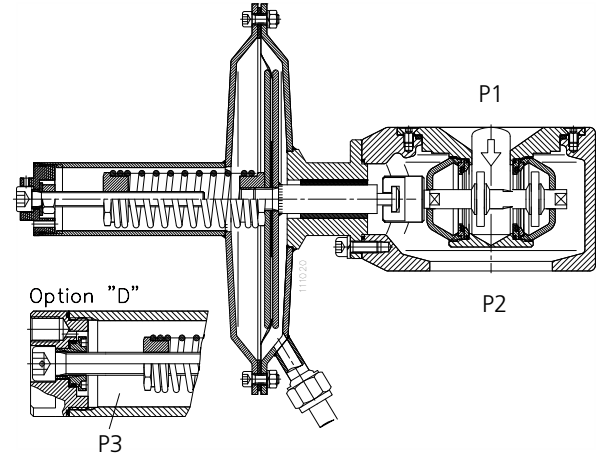
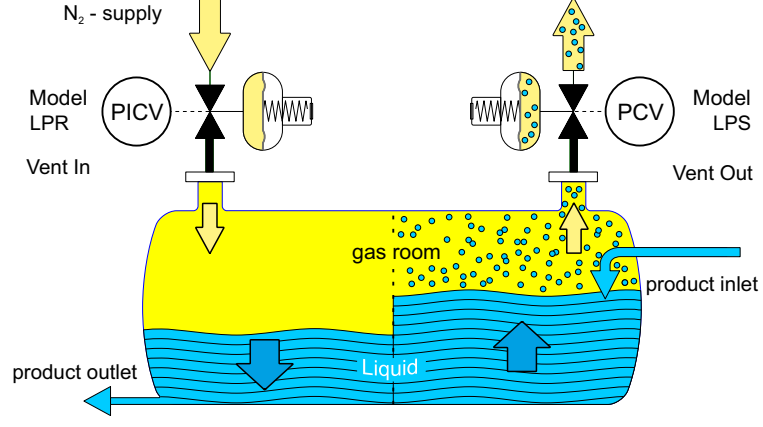

| Model dimensions | pressure connection | a | b | c | d | e | e | f Option "D" |
|----------------------------|---------------------|-------|------|-----|----|-----------|----------------------------------|----------------------|
| LP.W-050-...-L01(L02)-...- | DIN DN50 PN16 | ∅ 360 | ∅109 | 270 | 75 | ∅54 (M48) | always ∅54 (M48) with Option "D" | G 1/4" female thread |
| LP.W-050-...-L1-...- | | | | | | ∅38 (M36) | | |
| LP.W-050-...-M01-...- | | ∅ 204 | | 248 | | ∅54 (M48) | | |



MODEL CODE LPR[®]W wafer design DN 50

| 1 | | 2 | | 3 | | 4 | | 5 | | 6 | | 7 | |
|--------|---|--|-----|---------------|----|---------------------------|-----|----------|-----|---------|---|----------|----|
| Design | | Nominal diameter DN/ pressure connection | | Flow capacity | | Regulating pressure range | | Material | | Options | | Specials | |
| LP | W | - | 050 | - | .. | - | ... | - | ... | - | - | - | Xn |

2 Nominal diameter DN/ Pressure connection

| | | |
|---|---------|---|
| D | Flange: | DIN EN 1092-1, B1 DN 50 PN 10-40 |
| A | Flange: | ANSI B 16.5, 2" 150 lbs (can only be assembled with M14 bolts) |

3 Flow capacity

| | | | |
|----|------|--------|---------|
| 14 | Seat | ø14 mm | kv = 3 |
| 18 | Seat | ø18 mm | kv = 7 |
| 26 | Seat | ø26 mm | kv = 15 |

4 Regulating pressure range P2 (mbar)

| | With diaphragm M360 | With diaphragm M200 |
|-----|---------------------|---------------------|
| L01 | 2 - 10 | L05 8 - 50 |
| L02 | 4 - 20 | L10 16 - 100 |
| | | L20 30 - 200 |
| | | L50 80 - 500 |
| | | M01 200 - 1000 |

Flow table [flow quantities in Nm³/h]

| P1 [bar rel.] | 0.15 | 0.25 | 0.40 | 0.65 | 1.0 | 1.5 | 2.5 | 4.0 | 6.0 | 10 | Seat size |
|---------------|------|------|------|------|-----|-----|-----|------|------|------|-----------|
| 10 | 30 | 40 | 51 | 65 | 81 | 100 | 141 | 201 | 282 | 443 | ø14 mm |
| | 71 | 95 | 118 | 151 | 188 | 235 | 328 | 470 | 660 | 1030 | ø18 mm |
| | 151 | 198 | 252 | 323 | 402 | 500 | 705 | 1005 | 1410 | 2210 | ø26 mm |
| 100 | 19 | 33 | 46 | 63 | 80 | 100 | 141 | 201 | 282 | 443 | ø14 mm |
| | 44 | 76 | 108 | 146 | 187 | 235 | 328 | 470 | 660 | 1030 | ø18 mm |
| | 94 | 163 | 230 | 312 | 399 | 500 | 705 | 1005 | 1410 | 2210 | ø26 mm |
| 200 | - | 20 | 40 | 60 | 79 | 100 | 141 | 201 | 282 | 443 | ø14 mm |
| | - | 46 | 92 | 138 | 184 | 235 | 328 | 470 | 660 | 1030 | ø18 mm |
| | - | 99 | 197 | 295 | 394 | 500 | 705 | 1005 | 1410 | 2210 | ø26 mm |

The flow capacity is the same in the supercritical operating range (guide value: P2 < 0.5 x P1). It is recommended to design for operation at a maximum of 70% of the flow values.
P1 = supply pressure P2 = regulating pressure

5 Material (only the same colours can be combined)

| Housing/ internal components | Seat seal | Diaphragm/ Regulating range |
|--|--------------------------------|---|
| S 1.4408/ 1.4435 (1.4404) | K FFKM | P PTFE/ L.. |
| G 1.4408/ HC 22 (2.4602) | V FKM | E EPDM/ L.. M.. |
| H HC 22 (2.4602)/ HC 22 (2.4602) | E EPDM | G PTFE-glass fibre reinforced / L.. |
| | C FFKM con- forms to FDA | V FKM/ L.. M.. |

Example: Housing/internal components with material code "G" or "H" (red) are only combined with seat of type "K" or "C" and with diaphragm type "P" or "G".

Housing/internal components with material code "S" can be combined with all seat and diaphragm materials (yellow).

Pressure / flow characteristic

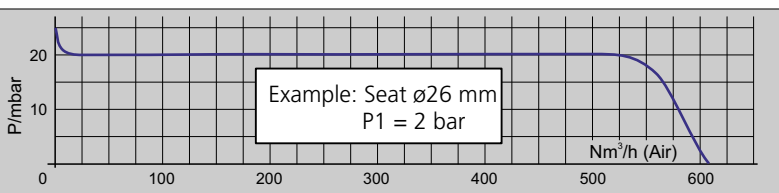

6 Options

| | |
|---|----------------------------------|
| D | Differential pressure connection |
|---|----------------------------------|

7 Specials

| | |
|----|--|
| X0 | If you require, for example, ATEX, PED, special connections, external control, rain hood, Adapter for Tri Clamp or SMS thread, please enter an X in this field with the number of desired Specials. Each of the specials must be described in writing. |
| X1 | |
| X2 | |
| Xn | For special versions and certifications, please contact the manufacturer or the appropriate sales representative. |

Installation

The preferred installation position is with vertical diaphragm housing and horizontal input. Pressure fixed unit is adjusted in this position. The output pressure increases by approximately 4 mbar (M200) respectively circa 15 mbar (M360) for installation with horizontal diaphragm housing. The installation position must be specified.

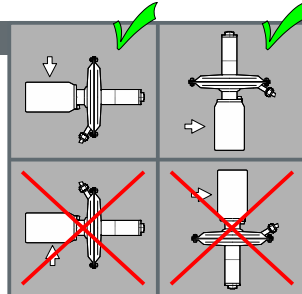

Mounting and start up

- Before connecting the pressure regulator please make sure
- LPRW adjust reduced pressure: (Relative pressure)
- 1.1 to compare the plant data with the name plate
- 2.1 set a light flow (2 Nm³ /h). Set the pressure +/- as required using a hexagonal wrench
- 1.2 the values marked on the name plate are the values measured during our functional inspection
- 2.2 the setting can be secured with a seal.
- 1.3 to check the corrosion resistance of the material
- 3 Adjust the LPRW differential pressure (-D) with the servo-regulator
- 1.4 to blow out impurities in the pipes
- 3.1 if the D-connection is pressurised with the servo-pressure, the working pressure is added by the servo-pressure.
- 1.5 to note the flow direction – it is marked with an arrow on the housing
- 1.6 to open inlet pipes slowly.